



## Nuclear Power for the Oilsands

Posted by [Stoneleigh](#) on May 26, 2007 - 11:04am in [The Oil Drum: Canada](#)

Topic: [Supply/Production](#)

Tags: [advanced candu](#), [nuclear](#), [oil sands](#) [[list all tags](#)]

This is a guest post by [Brian Wang](#) ([advancednano](#)).

In order for nuclear power to replace the burning of natural gas to power the extraction of oil from the oilsands involves about 4.4 GW of nuclear power per million barrels per day of oil extracted (according to Wayne Henuset, director of Energy Alberta Corporation, estimate of a 2.2 GW reactor separating 500,000 bpd). 10 million bpd would take about twenty 2.2 GW twin reactors. A detailed analysis is provided from the Nuclear Energy journal. It was written by Atomic Energy Canada and Canadian Energy Research Institute scientists.

A paper - [Opportunities for CANDU for the Alberta Oilsands](#) - from journal of Nuclear Energy (peer reviewed) is probably the definitive word on how much oil would be separated using a CANDU reactor.

SAGD can recover over 50% of the initial volume of crude bitumen in place. An average steam/oil ratio of 2-3 is required. Working from output levels of high quality steam of 62400 m<sup>3</sup>/day, a cumulative steam/oil ratio of 2.5, operating capacity of 93%, the results was consistent with a 146,000 barrel per day bitumen production.

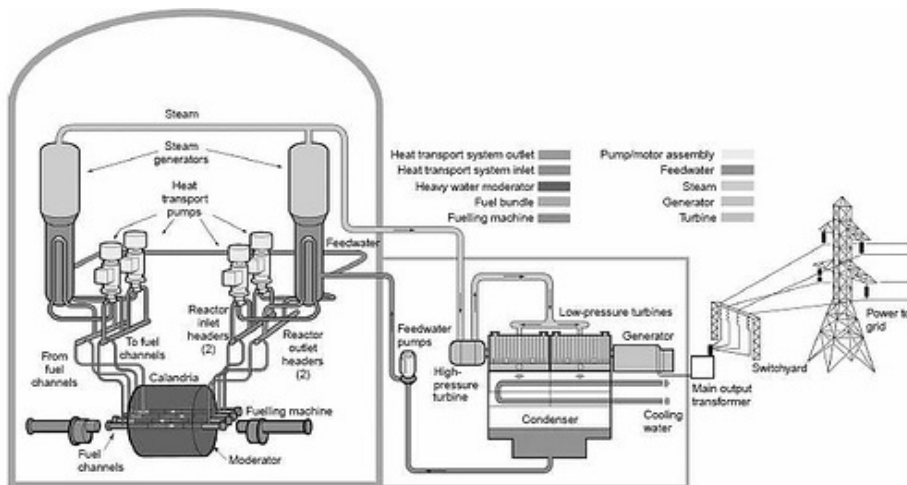

Fig. 1. Schematic of typical ACR plant

A typical advanced CANDU reactor

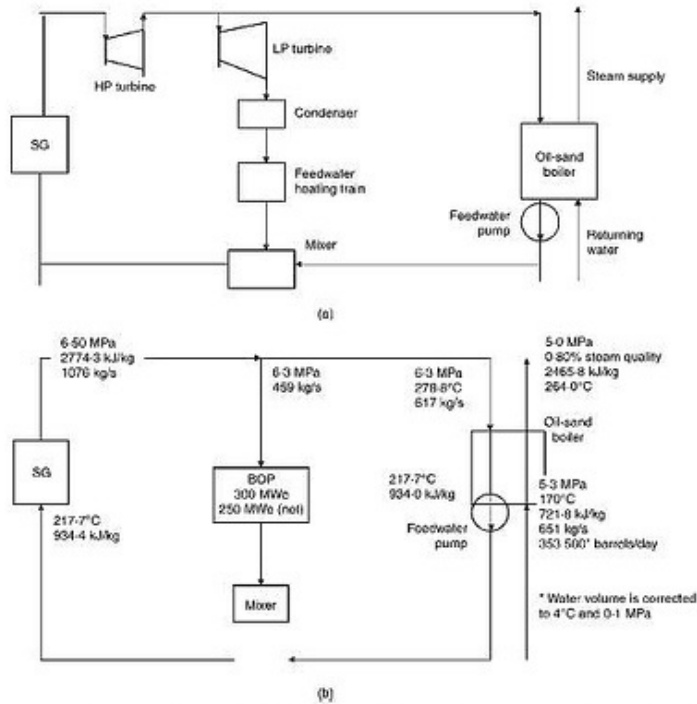

Fig. 2. Co-generation configuration diagram for: (a) scenario with lower steam pressures and smaller-scale electricity production; and (b) scenario with high steam pressures and/or a greater degree of electricity production or lower steam delivery

### Configuration of a reactor as part of oilsands project

A 728 MWe (gross) nominal electric output ACR-700 design generates 1983 MW (thermal). The CANDU reactor can be adapted to provide steam of 2-6 MPa. An ACR700 would provide in one configuration 140MWe (net), 420,000 barrels/day/steam and supply pressure of 2.2 MPa. The production rate of bitumen using this steam would depend on the steam/oil ratios required in the SAGD wells. For steam/oil ratios of 212.4-224 degrees celsius the bitumen production rates would be 168,000-210,000 bbl/day. The project would achieve a 10% advantage in steam cost even if natural gas were at USD3.25/mmbtu.

The twin 2.2 GWe reactor proposal would generate 507,000 to 634000 bbl/day in a similar configuration with similar assumptions.

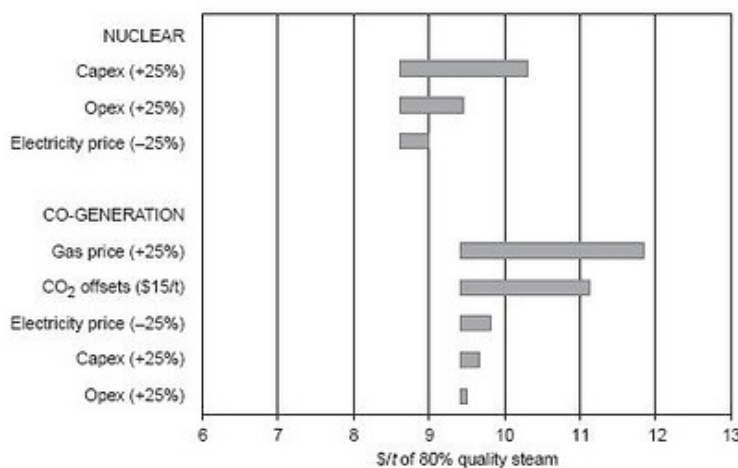

Fig. 3. Steam supply cost sensitivities

### Cost Sensivity of the project

"One reactor (would be) in 2016 and the second one would be in 2017 ... We're taking it to where we feel there's less resistance (from the public)," corporation director Wayne Henuset [told](#)

[Reuters](#).

"We hope to site it and talk to the communities in the next two months," he said in an interview on the sidelines of a nuclear industry seminar.

Two further reactors are planned for a later unspecified date.

Canada's Natural Resources Minister Gary Lunn told Reuters in January that, in theory, he liked the idea of nuclear power for the oil sands.

Henuset said Atomic Energy of Canada Ltd. -- the government-owned manufacturer of the Candu -- estimated it could build the first reactor in 36 months.

He also said he hoped that nuclear waste from the plant would be stored either on site or in special chambers until it could be reused.

Shell Canada Ltd. Chief Executive Clive Mather told Reuters in January that although he was not ready to buy into the nuclear concept, it could offer a price advantage over time. Shell is a major oil sands operator.

The World Nuclear Association estimates natural gas is [60 percent](#) of an oil-sands facility's operating costs.

A new Steam Assisted Gravity Drainage (SAGD) process has been developed and proven in Canada during the last decade. [It is compatible with the steam conditions](#) from CANDU reactors would release about 0.10 tonnes/barrel for extraction and upgrading of bitumen from much deeper deposits.

Reviewing the short history of oil sands production suggests that, based on current production and past rates of growth, production in 2050 would reach about 1.5 billion barrels/year (4 million bpd). About half would come from in situ projects. Presuming the production rate increases at a higher than historical rate of 5%/year, compounded annually, results in production of 3 billion barrels/year (8 million bpd) by 2050.

A single large dedicated CANDU 9 reactor could supply the steam and electricity to extract and upgrade about 600 million barrels of bitumen over a period of 30 years. The land area from which bitumen would be extracted is about 18 square miles requiring steam distribution and bitumen recovery piping from a centrally located 60,000 barrel/day plant of up to about 3 miles. Smaller reactors would be suitable for smaller production rates with shorter piping distance.

*[Henuset is quoted](#) as saying that the 2.2 GW twin reactor would separate up to 500,000 barrels of oil a day.*

In a [speech](#) to a high-powered business audience in New York last week, Prime Minister Stephen Harper said production from the oil sands — which now supply about one million barrels of crude a day — is now "on its way" to four million barrels by 2015, a target that exceeds the bullish 3.5 million barrels forecast used by the Canadian Association of Petroleum Producers.

[Here is a pdf of a Wayne Henuset speech](#)

The National Energy Board has forecasted that the oil sands production would increase fourfold by 2015, largely using steam assisted gravity drainage. If all the SAGD projects planned were to use natural gas as the fuel in cogeneration systems that would see natural gas demands in the region skyrocket to over 3 billion cubic feet/day by 2015. That's more natural gas than all the rest of Alberta uses now. 375 million cubic feet/day is replaced by the 2.2GW reactor. USD1.095 billion/year for the 375 million cubic feet/day if natural gas is at [\\$8 per 1000 cubic feet](#).

[\[1000 cubic feet of natural gas is equal to 293 kWh.](#)

320 billion kWh per year in 2015. Twenty 2 GW reactors needed to fully replace the natural gas usage]

Putting the brakes on the oil sands development is not the answer. Canada needs the oil sands. Conventional oil and gas reserves are declining. Energy conservations are important and necessary but they won't eliminate the need for fossil fuels in our economy. In addition, oil sands activities will lead to significant economical impact not only to Albertans but across the nation with substantial increase in gross domestic product, employment generating over \$123 billion in tax revenues.

It makes no sense to squander precious and declining reserves of natural gas to make oil in the oil sands. That's simply like burning gold to make coal. The answer for this is using nuclear power.

The first strategy is using CANDU nuclear electricity generation to extract the oil from the carbonate triangle involving potentially 450 [billion] barrels of bitumen. This is new. The second strategy is generating hydrogen electricity for the upgrading of the bitumen. The third is providing steam supply for the SAGD process in the oil sands; and finally, generating electrical needs for the utility companies in Alberta to keep up with our provinces projected growth.

One ACR1000 reactor would result in an annual displacement of around 500 million tons of CO2 compared to an equivalent gas fired generator accounting to a savings of \$100 million, annually, of carbon dioxide cost if it was at \$20.

So either you burn natural gas to get at oil from the oilsand OR you use new processes where you burn some of the oilsand to get oil from it OR you make a lot of nuclear reactors. If oil prices stay high and we go past peak oil and the prices go higher then it seems that making the nuclear reactors to extract the most oil for other purposes is the way to go. If all current conventional oil in North America had to be replaced with oil from the oilsands that would be about 24 million bpd. 9 billion barrels per year. If Henuset/AECL/CERI are correct in the 500,000-630,000 bpd estimate then 48 of the 2.2 GW twin reactors would be needed for the SAGD extraction process.

One way of viewing nuclear powered oil sands is to think of it as making a hybrid version of the global energy system.

Addendum on Water Supply

[Of the total water allocated in the province](#), the oil and gas sector actually uses less than half of one per cent for water and steam injection processes (enhanced oil recovery). Water used for these purposes has declined from 88.7 million cubic metres in 1973 to 47.5 million cubic metres in 2001 – 37 million cubic metres of this was non-saline (fresh) water, 10.5 million was saline or

brackish water. (Source: Water Use for Injection Purposes in Alberta report, Alberta Environment, 2003)

[A CANDU reactor would \(700MW\) would generate 420,000 barrels per day of steam.](#) A cubic meter is [8.38 barrels](#). Therefore, the (700MW) reactor would generate 18.3 million cubic meters of steam per year. 57.4 million cubic meters of steam for the 2.2 GW twin reactors. [Water expands to 1700 times its volume in steam.](#)

So the 2.2 GW reactor would be using 33,800 cubic meters of water for that amount of steam. Scaling up that amount of water usage 100 times would be well within the bounds of the water allocated for steam and water injection. The steam for the nuclear plants does not seem to be the limiting factor. Also, as I not further down this article 90% of the water can be recovered and recycled in the SAGD process.

The oil and gas industries complete allocation is 432.4 million cubic meters of water. (4.6% of 9.4 billion cubic meters of water).

The oil and gas industries gets 178.6 million cubic feet of water for steam and water injection. (1.9% of 9.4 billion cubic metres of water). This amount could get increased if needed.

If agriculture had to give up some of its water allocation, then in theory 33% of the the 9.4 billion cubic meters of water might go to oil and gas. The re-allocation can be reduced by using wastewater from the 11% of the water (1 billion cubic meters) that is used for people in their homes could be used. The oilsands industry could then be scaled up 65 times from 2001 levels even still using the same wasteful methods as used in 2001.

[Up to the end of 2001, Alberta had allocated over 9.4 billion cubic metres of water annually for a variety of uses.](#) Allocations from surface water sources account for 98 per cent of this total; the remaining two per cent are from groundwater sources.

For 2001, the oil and gas sector was licensed to use 4.6 per cent of all the water allocated in Alberta; less than half (1.9 per cent) of this water is allocated for water and steam injection operations. By comparison, the agriculture sector (including irrigation) was licensed to use the largest amount of water of any economic sector, at approximately 46 per cent. Municipal water supplies accounted for 11 per cent.

[On page 25 of this report \(Technology roadmap for the oilsands\)](#), it has chart which shows that thermal (steam) extraction of oilsands was using about 7 million cubic meters of water. This produced 125000 bpd. Scaled up 200 times, it would be 1.4 billion cubic meters of water, or 15% of Alberta's water. It would mean re-allocating water or re-using wastewater or recycling more of the SAGD water and being more efficient, but it is feasible. Especially if there was great need because of any potential peak oil situations.

A criticism of some of this is that "even the oil industry is not looking at more than 4 million bpd from the oilsands". That is because the oil industry does not believe in peak oil. They are looking at 4 million bpd and thinking about new markets they would need to find to sell it.

So in summary, (since all the dots connections have to be spelled out):

1. There is plenty of water to scale up, even if water inefficient processes from 2001 are scaled up.
2. The water/steam for the nuclear reactors is not that large a demand and can be scaled up and the nuclear reactor/SAGD process is more water efficient than current oilsand methods
3. The steam from cooling any nuclear reactor used for SAGD can be 90% recycled
4. The water for the nuclear reactors can be wastewater
5. The SAGD process is more water efficient than other methods currently in use in the oilsands.

Also reviewing the other points that I have made in this thread:

In March 2006, [Canada's leading private sector companies](#) in the nuclear and power plant field, Babcock & Wilcox Canada, GE Canada, Hitachi Canada and SNC-Lavalin Nuclear joined together with Atomic Energy of Canada Limited (AECL) to create Team CANDU. The financial backing from those companies means that cost overruns will be borne by them and not by the Canadian tax payer.

The project (the first 2.2 GW twin reactors) is expected to cost C\$5.5 to 6.2 billion.

The 6 most recent CANDU reactors in S Korea and China were on time and on budget.

Another point is that a CANDU reactor [Can generate 30-40% more energy from Light water reactor "waste" or unburned fuel](#) and CANDU reactors can also breed Thorium.



This work is licensed under a [Creative Commons Attribution-Share Alike 3.0 United States License](#).